

301 SERIES

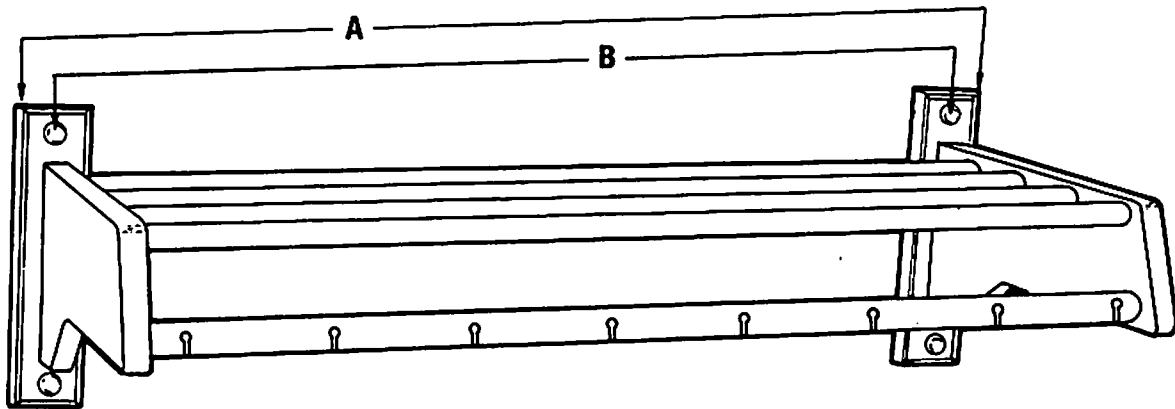

MODEL NO.	SIZE	A	B	MIN. CLOSET WIDTH	MIN. ALCOVE WIDTH*
CP30124	24"	25½"	23¼"	27¾"	26"
CP30130	30"	31½"	29¼"	33¾"	32"
CP30136	36"	37½"	35¼"	39¾"	38"
CP30142	42"	43½"	41¼"	45"	44"
CP30148	48"	49½"	47¼"	51"	50"

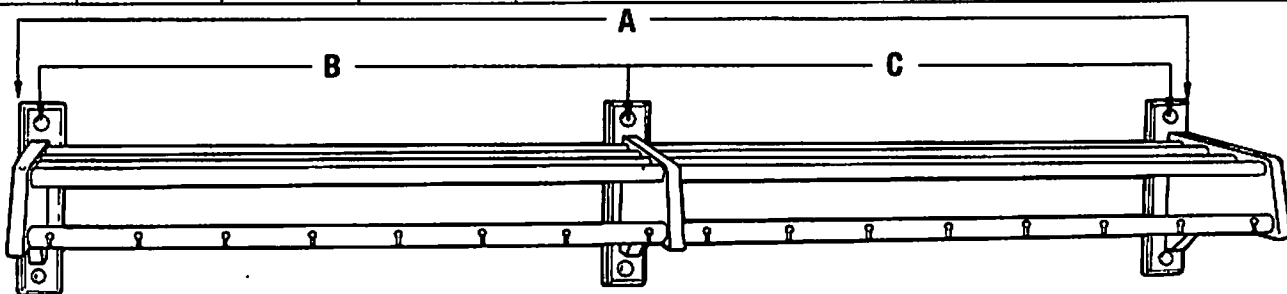

MODEL NO.	SIZE	A	B	C	MIN. CLOSET WIDTH	MIN. ALCOVE WIDTH*
CP30160	60"	61¼"	29⅞"	29⅞"	62¼"	61¾"
CP30172	72"	73¼"	35⅞"	35⅞"	74¼"	73¾"
84" and 96" sizes available upon request.	84"	85¼"	41⅞"	41⅞"	86¼"	85¾"
	96"	97¼"	47⅞"	47⅞"	98¼"	97¾"

*The entrance of the alcove must be the same width as the interior.

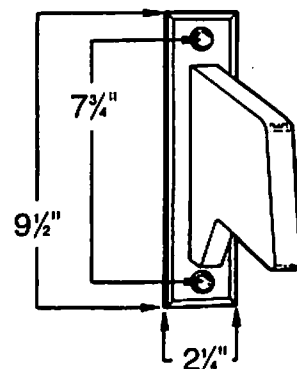
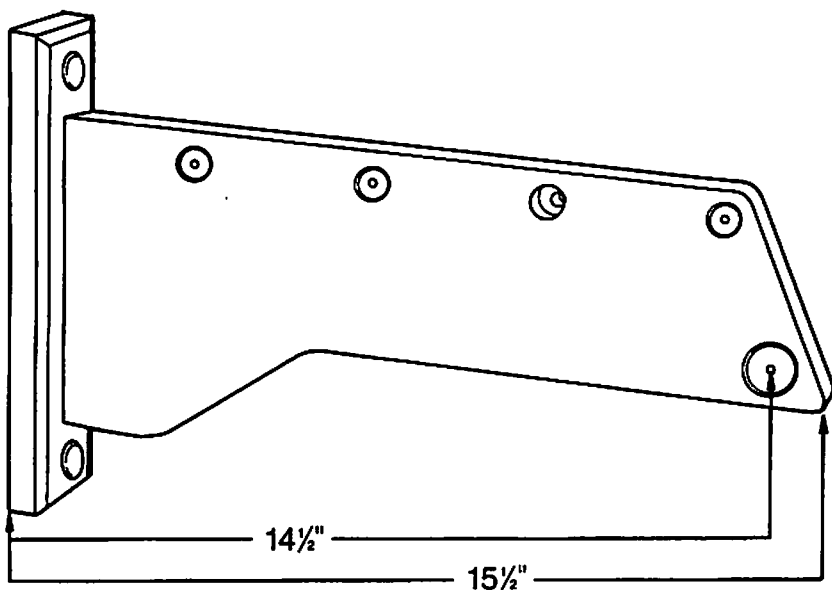

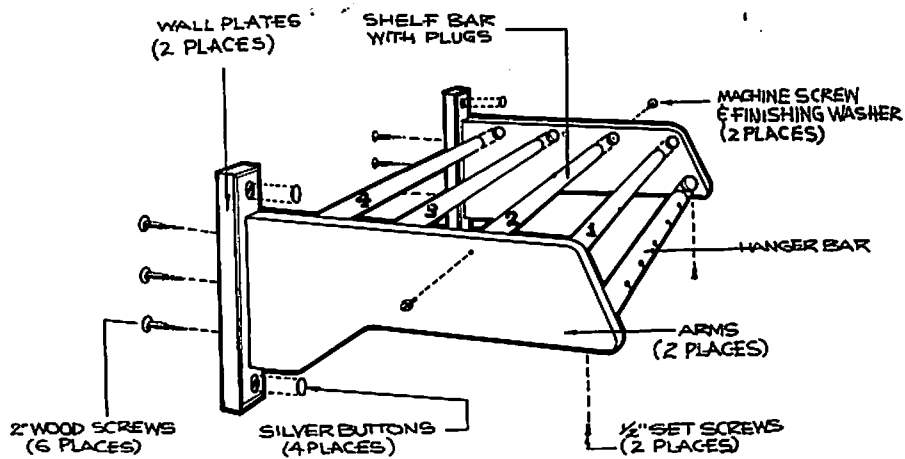

N O . 3 0 1 S E R I E S

- 1) Screw wall plates onto arms using three 2" wood screws for each arm.
- 2) Lay the left hand arm on its' side. Select the shelf bar which contains the plugs and insert it into position #2. Insert the 3 remaining shelf bars and hanger bar. Be sure the hanger bar is positioned as illustrated above.
- 3) Being VERY CAREFUL not to scratch finish, insert right hand arm onto the shelf and hanger bars.
- 4) Secure the #2 shelf bar to each arm with the two $\frac{1}{4}$ " machine screws and finishing washers.
- 5) Insert the hanger bar set screws. Be sure the hanger bar is positioned so that the set screws will enter the bottom slot of the hanger bar.
- 6) After mounting assembled unit on wall, insert silver buttons into top and bottom holes on wall plates.
- 7) If hangers do not slide freely in hanger bar, check bottom slot for a restricted area. Insert screwdriver into restricted area and carefully rotate screwdriver just enough to widen restriction.